



DECENTRALIZED

## Heat recovery unit VENTBOX 800 Public

- clean air for schools, kindergartens and offices
- high efficiency up to 88 %
- automatic control of CO<sub>2</sub> levels
- detection of radon and relative humidity

The decentralized heat recovery unit **VENTBOX 800 Public** is designed for installation in enclosed spaces of school buildings and other public spaces. It meets strict hygienic limits for acoustic emissions and air filtration. **Ventilation performance, low acoustic emissions, compact dimensions and efficient heat recovery allow installation even in buildings, where extensive air ducts cannot be built.**

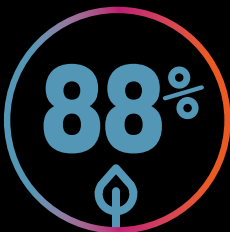

**High efficiency of recovery**

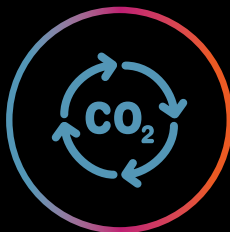

**Automatic operation control according to the CO<sub>2</sub> levels in the room**



**Low energy consumption and minimal noise**



**Simple installation without the need for air ducts**

# VENTBOX 800 Public

## Specification

<b>Dimensions</b>	1 940 × 1 005 × 740 mm
<b>Max. airflow</b>	800 m <sup>3</sup> /h
<b>Preheating</b>	integrated, maximum preheating power 3.5 kW
<b>Circuit breaker</b>	16 A–230 V
<b>Network communication</b>	Modbus TCP/IP
<b>SFP</b>	0.18–0.29 W/m <sup>3</sup> /h
<b>Control</b>	via web interface (time modes, automatic control according to the concentration of CO <sub>2</sub> , radon, and humidity)

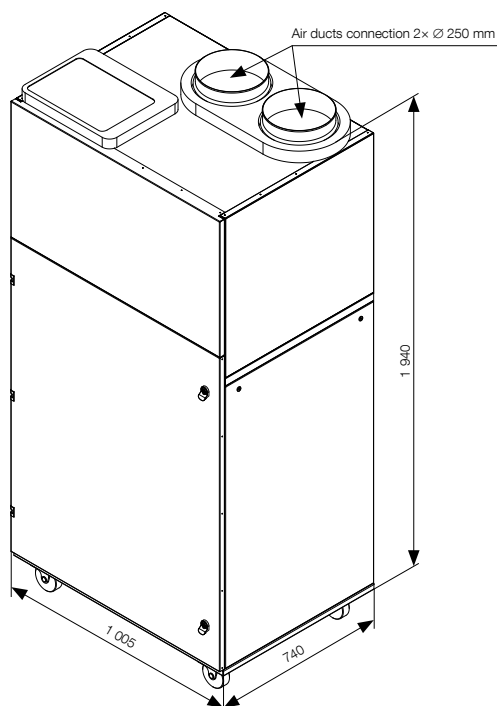

The VENTBOX 800 Public ventilation unit has its own solution for connecting exterior air inlets, for example through a window infill. The termination of air ducts on the outside of the building is always done with a requirement for aesthetic appearance and functionality. The ventilation unit is equipped with an efficient heat exchanger and reduces heat losses that occur during conventional ventilation 'only by opening windows' or other economically and technically unsuitable methods of ventilation. **It ensures a permanent reduction in CO<sub>2</sub> concentration and maximum elimination of outdoor odors using carbon filters and brings the comfort of fresh clean air.** The installation of a unit with an enthalpy exchanger does not require connection to a waste pipe for condensate drainage.

## Decentralized heat recovery unit variant

- suitable for schools, kindergartens, halls, training centers, libraries, and offices up to 600 m<sup>2</sup>
- low noise (integrated noise suppressor for interior and exterior)
- high efficiency of heat recovery up to 88 %
- version Premium – a more sophisticated version of the unit, equipped with unique EC motors with constant flow function, compensating for pressure losses including filter clogging indication
- decentralized solution – simple installation without the need for duct installation
- low weight, easy handling (the top part of the silencer can be separated from the motor part)
- optional enthalpy exchanger with heat and humidity recovery, without the need for condensate drainage and the need for electric preheating (operation down to -10 °C)
- standard exchanger equipped with automatic frost protection with intelligent control of the PTC heater
- F7 class filters with a large filtration range – pollen, odor, bacteria, mold
- automatic bypass

## Centralized heat recovery unit variant

- suitable for family houses with an indoor pool, administrative buildings, schools, kindergartens, cafes up to 600 m<sup>2</sup>
- the unit is available in a more sophisticated Premium version, which is equipped with unique EC motors with a constant flow function, compensating for pressure losses, including filter clogging indication with connection to air ducts 4x 250 mm
- dimensions 1 260 × 1 005 × 750 mm

Unit power [%]	External pressure [Pa]	Airflow [m <sup>3</sup> /h]	Power input [W]	SFP [W/m <sup>3</sup> /h]	Heat recovery efficiency			
					With standard heat exchanger according to EN 13141-7		With enthalpy heat exchanger according to EN 13141-7:2011	
					Heat η <sub>t</sub> [%]	Humidity η <sub>x</sub> [%]	Heat η <sub>t</sub> [%]	Humidity η <sub>x</sub> [%]
15	50	120	19	0.16	80.8	–	85.0	77.8
70	50	560	106	0.19	81.8	–	78.5	62.5
100	50	800	239	0.30	81.6	–	76.2	56.3
100	200	800	318	0.40	81.6	–	76.2	56.3



member of KORADO Group

**LICON s.r.o.**  
 Svárovská 699  
 463 03 Stráž nad Nisou  
 Czech Republic  
 e-mail: info@licon.cz  
[www.licon.cz](http://www.licon.cz)  
[www.thermwet.cz](http://www.thermwet.cz)



@licon.cz



@liconcz



Technical changes reserved.